



AET Electric PTE LTD

# K-Factor Isolation Transformer

## Dry Type Transformers



# “ A Manufacturer of High Quality Transformers in Singapore ”

Manufacture and sale of transformers, mainly dry type, with a wide and diverse areas ranging from electronic manufacturing, data centers, marine, petrol chemical industries and offshores applications.

We have been manufacturing transformers since 1980. Through the years of dedication to this highly specialized field, our company had acquired knowledge and experiences in this field.

We work with a variety of clients including engineers, architects, facilities personnel, and end-users. Industries we serve include financial, education, manufacturing, utility, communications, broadcasting, government and even retail.



## Our Quality

We had achieved approvals from recognized international bodies from ABS(American Bureau of Shipping), LR(Lloyd's Registrar), DNV, BV(Bureau Veritas) , NKK(Nippon Kaiji Kyokai), RINA, GL(German Lloyd), RMRS and PSB



We adopt strict quality assurance and control measures in our manufacturing process to ensure consistency and reliability in our products and services to meet the needs and requirements of our customers. We had also been awarded the ISO9001:2000 Certification in design, manufacture and repair of transformers. Certified by DNV(Det Norske Veritas) Cert no. 3202-2007-AQ-SIN-RVA

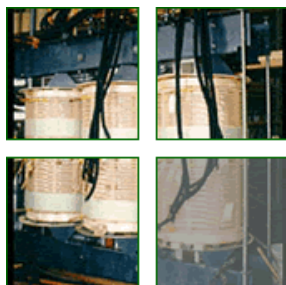

With our complete setup and quality assurance, we are flexible and capable to meet your special requirements.

## Why Choose AET transformers?

Our competitive advantage lies on

- Our vast experience in designing our transformer
- Use of highest quality materials
- Stringent testing procedure
- Short leadtime
- ISO certified and manufactured in Singapore
- After sales service

### High Grade Iron Core

- High Grade, Cold rolled, Grain Oriented steel sheet with low specific losses, insulated on both sides by thin organic coating from Kawarin, Japan

### High Grade Copper Windings

- Copper Strips with 200°C enameled coated from Invex, Italy. The copper conductors are fully sized, transposed and shaped to minimize Eddy current losses.

### Insulation Materials

- Class H (NOMEX from Dupont) Insulation material is used between overlapping layers.
- Axial channels are used between layers of primary and secondary winding to provide air gap for uniform cooling.
- High temperature tolerant fiberglass boards are used as bobbins to separate the core and windings.
- Fully impregnated with class H varnish and oven dried.

### Terminals

- Tinned Copper Busbar (For 100KVA and above)

### Protection Devices(Optional)

- Thermal protection devices
- Thermister (Normally Closed, activated at 160°C)
- Digital Temperature Controller with 2 x Voltage Free contacts
- Inrush Current Limiter (Available in Auto or Semi-Auto Type)



Temperature Controller, TR42

### Testing Procedure

- Insulation Test at 1000Vdc and
- Hi-potential test at 3KV
- Resistance Test
- Open circuit Test (No-load Test)
- Short circuit Test
- Temperature Rise Test
- Noise Level Test

## Why use K-Factor transformers?

Harmonics are generated by the use of computers, servers and non-linear devices. These harmonics will cause excessive heating and degrade the insulation materials in the transformer which eventually lead to transformer failure.

### Determine K-Factor

Defination(From UL1561)

A rating applied to a transformer indicating its suitability for the use of non sinusoidal loads. In other words,

$$K - Factor = \sum_{h=1}^{\infty} I_{h(PU)}^2 h^2$$

Where

$I_{h(PU)}$  is the rms current(in per unit) at harmonic,  $h$

$h$  is the harmonic order

Example of The Load Capability of a K13 Transformer(From IEEE C57.110-1998 Section 6)

Harmonic order $h$	PU rms current $I_{h(PU)}$	$I_{h(PU)}^2$	$h^2$	$I_{h(PU)}^2 h^2$
1	1.000	1.00000	1	1.0
3	0.333	0.11111	9	1.0
5	0.200	0.04000	25	1.0
7	0.143	0.02040	49	1.0
9	0.111	0.01234	81	1.0
11	0.091	0.00826	121	1.0
13	0.077	0.00592	169	1.0
15	0.067	0.00444	225	1.0
17	0.058	0.00346	289	1.0
19	0.053	0.00277	361	1.0
21	0.477	0.00227	441	1.0
23	0.043	0.00189	529	1.0
25	0.040	0.00160	625	1.0
Summation, $\sum$		1.21448 DC loss Factor		13 K-Factor

## Harmonics Effects on Transformer

The presence of harmonics will cause the increase in losses and heating. They will increase both the load loss(impedance loss) and no-load loss(excitation).

### a) Load Loss

Load Loss includes skin effect, increased winding eddy current( $P_{EC}$ ),  $I^2R(P_{DC})$  and stray losses( $P_{OSL}$ )

From IEEE C57-110, total load loss consist mainly winding eddy current loss, and  $I^2R$  loss. Stray losses can be neglected in dry type transformer

### b) No Load Loss

No load loss is increased due increasing of hysteresis loss . The presence of harmonics increase the flux density and the rate of change of core magnetization which result in increased of hysteresis loss.

## In Our Design

In order to reduce the effects of harmonics, our K-Type Transformers ,DTKF™ series are specially designed

### For Load Loss

- Parallel individual insulated copper conductors are used to reduce skin effect and eddy current losses
- Larger conductors are used to reduce  $I^2R$  losses
- Static Shield between the PRI & SEC winding to reduce electrostatic noise caused by the harmonics
- Well ventilated by using axial channels and internally gapped per turn winding
- 200% neutral conductor to handle zero sequence currents flow

### For No Load Loss

- To reduce hysteresis loss, our transformer is designed at a lower flux density and use of high grade iron core.

### For Low Inrush Current

- Designed at a lower flux density and use of high grade iron core with high core saturation point.
- Primary winding is wound externally to increase the primary impedance path

## Our Transformer Construction

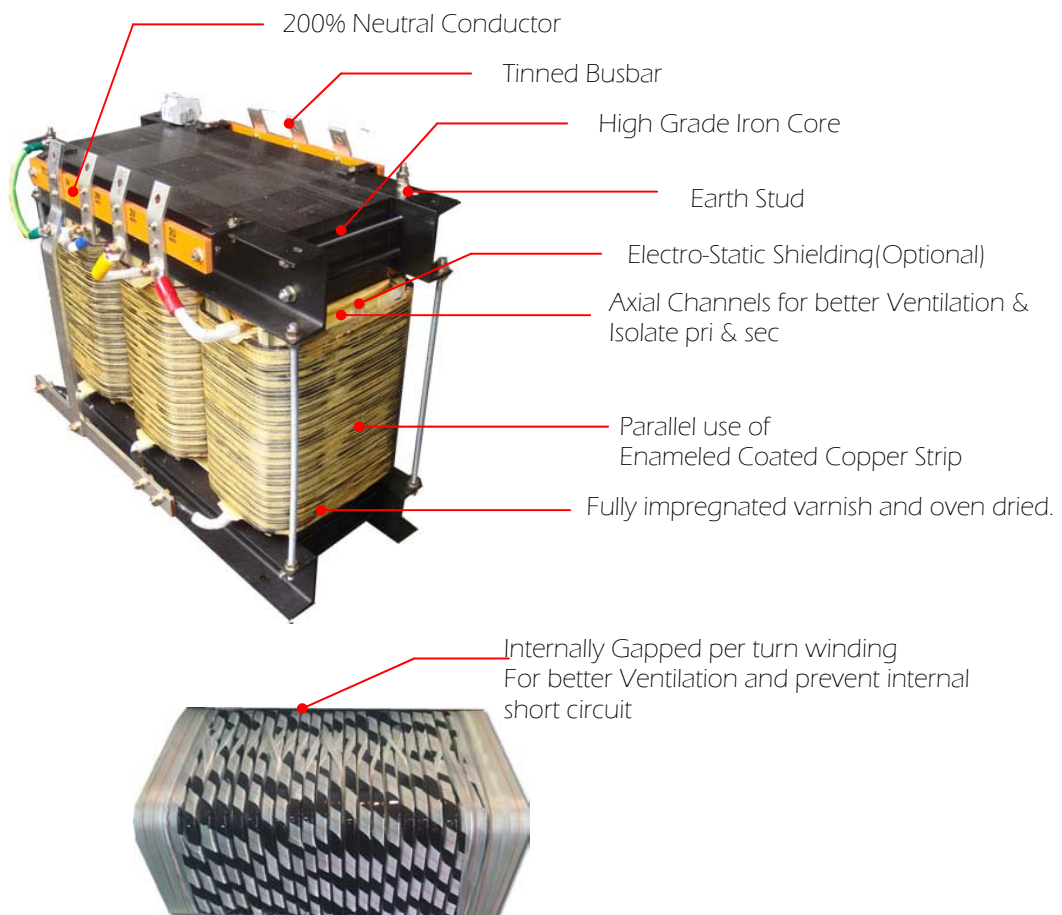

# Our Complete System

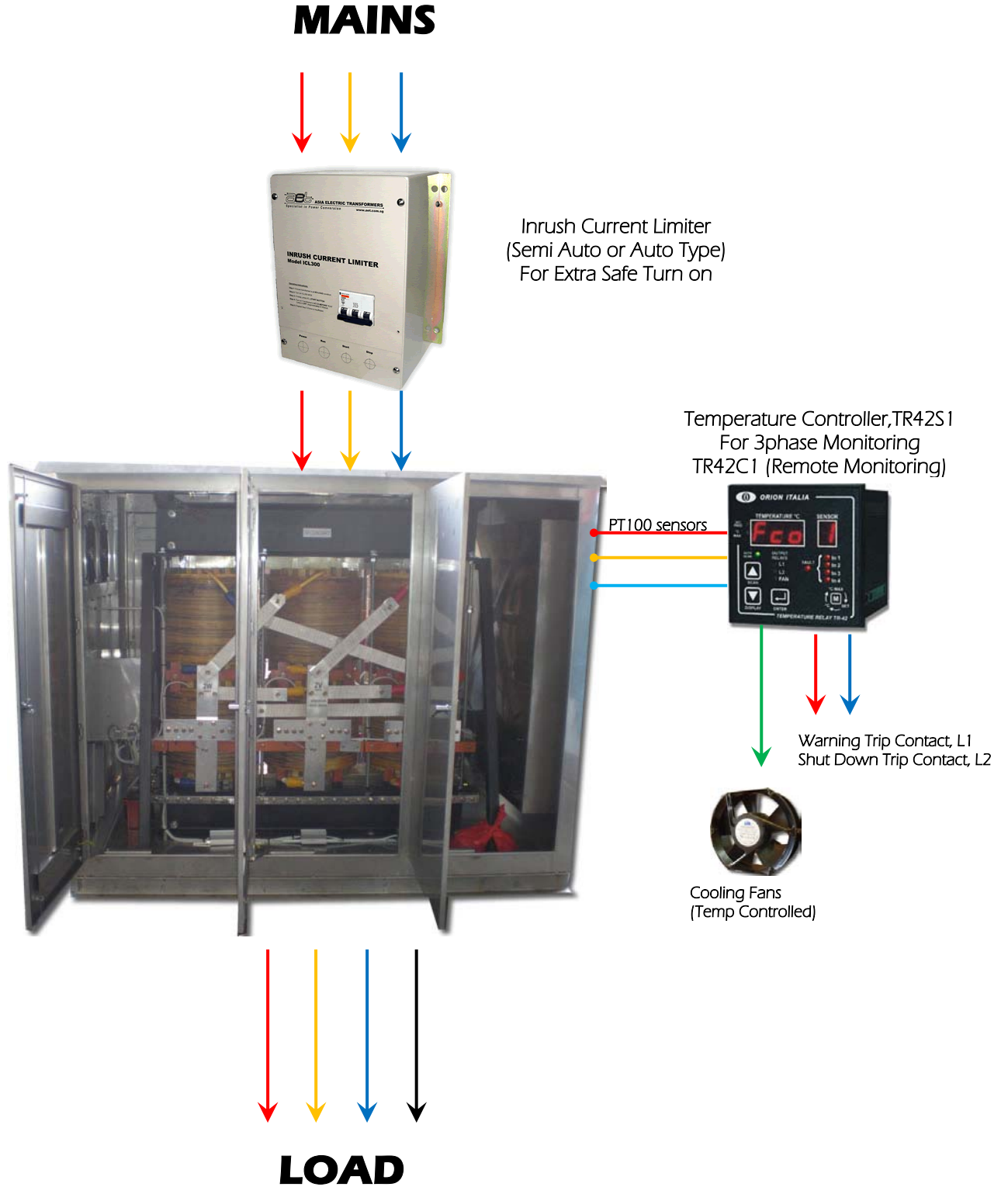

**Specifications – K13**

Rated Power (Kva)	<b>40</b>	<b>60</b>	<b>70</b>	<b>80</b>	<b>100</b>	<b>120</b>	<b>180</b>	<b>200</b>	<b>250</b>	<b>300</b>	
Rated Primary Voltage	400Vac										
Secondary Voltage (At No Load)	400Vac(230Vac-N) Neutral Conductor Size 200% bond to ground										
Voltage Regulation	< 2%										
Input Voltage Tolerance	+10% ie ( 0V to 440V)										
Rated Current	58	87	101	115	144	173	260	289	360	433	
Frequency	45-65Hz										
Vector Group	Dyn11(-30 deg Phase Shift) / Dzn0( Zero phase Shift)										
Insulation Type	H										
Test Voltage	3kVac, 1 min										
Enclosure Protection Degree	IP21										
Max Ambient Temperature(°c)	40										
Max Allowable Temperature Rise(°c)	120										
Approx Impedance Voltage (%)	< 5										
Standard in accordance	IEC 60076-11 ; IEEE C57-110 ; UL1561										
Approx Losses (W)	No-load Iron losses	250	350	400	450	600	750	900	1000	1100	1300
	On-Load Copper losses	600	900	1100	1300	1500	1700	2800	3000	4500	5800

**Specifications – K13**

Rated Power (Kva)	<b>400</b>	<b>500</b>	<b>600</b>	<b>700</b>	<b>800</b>	<b>900</b>	<b>1000</b>	<b>1200</b>	<b>1500</b>	<b>2000</b>	
Rated Primary Voltage	400Vac										
Secondary Voltage (At No Load)	400Vac(230Vac-N) Neutral Conductor Size 200% bond to ground										
Voltage Regulation	< 2%										
Input Voltage Tolerance	+10% ie ( 0V to 440V)										
Rated Current	577	721	866	1010	1154	1300	1443	1732	2165	2886	
Frequency	45-65Hz										
Vector Group	Dyn11(-30 deg Phase Shift) / Dzn0( Zero phase Shift)										
Insulation Type	H										
Test Voltage	3kVac, 1 min										
Enclosure Protection Degree	IP21										
Max Ambient Temperature(°c)	40										
Max Allowable Temperature Rise(°c)	120										
Approx Impedance Voltage (%)	< 5										
Standard in accordance	IEC 60076-11 ; IEEE C57-110 ; UL1561										
Approx Losses (W)	No-load Iron losses	1300	1500	1700	1850	1950	2050	2200	2500	3000	5000
	On-Load Copper losses	5700	6800	7500	8500	11000	15000	18000	22000	28000	35000

### Winding Schematic

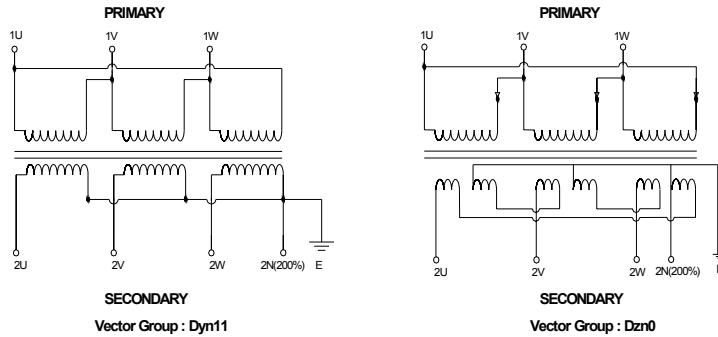

### Dimensions and weights

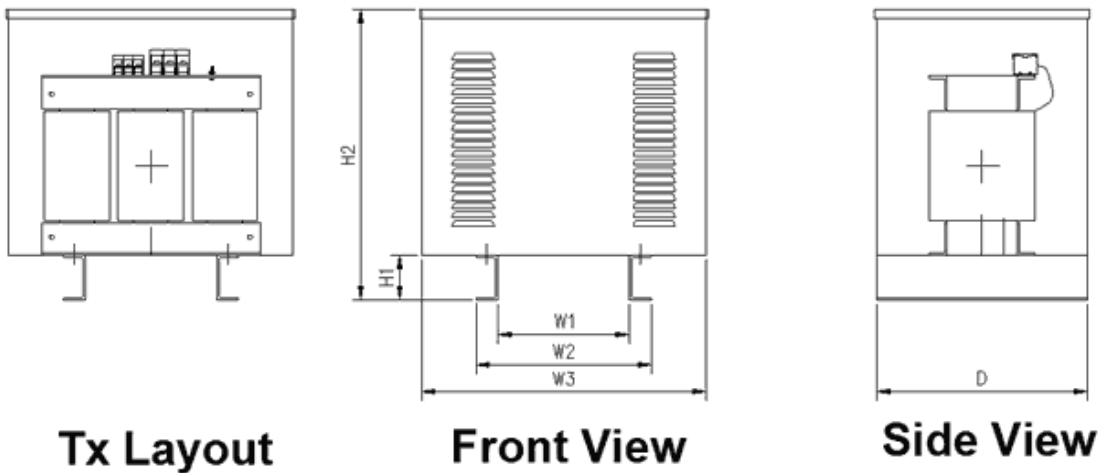

Rated power (kVA)		40	60	70	80
Dimensions (mm)	W1	300	300	400	560
	W2	400	400	500	660
	W3	650	700	750	800
	D	500	550	550	600
	H1	100	100	100	100
	H2	650	750	750	850
Approx Weight (Kg)		280	450	500	600

Dimensions and weights

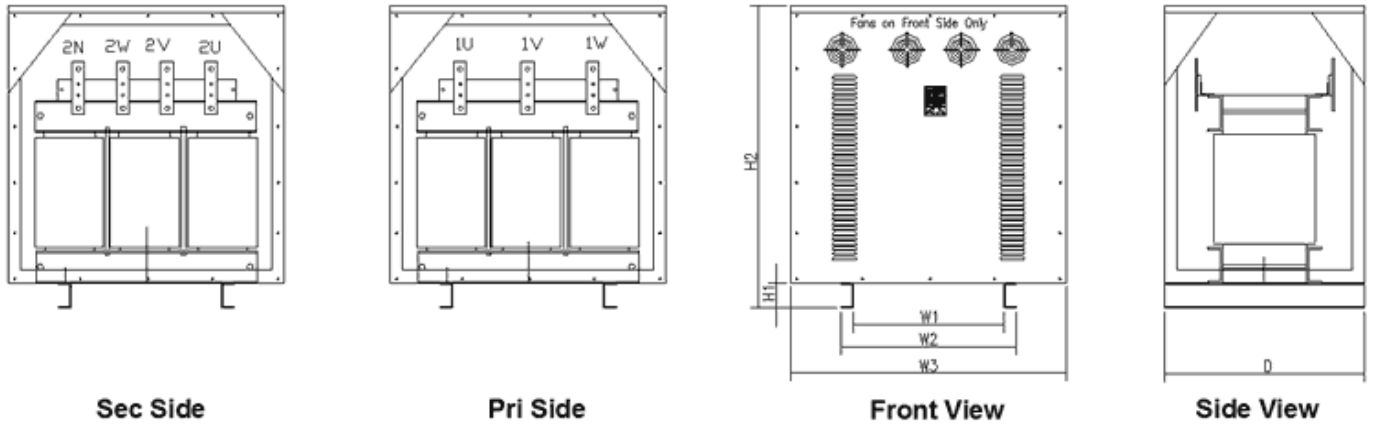

Rated power (kVA)		100	120	180	200	250	300	400	500
Dimensions (mm)	W1	560	560	600	600	700	750	850	850
	W2	660	660	700	700	800	850	950	950
	W3	950	950	1050	1100	1250	1300	1400	1400
	D	600	600	800	800	850	900	900	900
	H1	100	100	100	100	100	100	100	100
	H2	950	950	1250	1350	1350	1350	1500	1500
No of fans		Nil	2x4"	2x6"	2x6"	3x6"	3x6"	4x6"	4x6"
Approx Weight (Kg)		600	700	950	1100	1300	1600	1800	2000

Rated power (kVA)		600	700	800	900	1000	1200	1500	2000
Dimensions (mm)	W1	900	1000	1000	1000	1000	1000	1050	1050
	W2	1000	1100	1100	1100	1100	1100	1150	1150
	W3	1600	1700	1800	1800	2000	2000	2000	2200
	D	1000	1150	1200	1200	1300	1300	1400	1500
	H1	100	100	100	100	100	100	100	100
	H2	1600	1600	1600	1700	1800	1900	2000	2100
No of fans		4x6"	6x4"	6x6"	6x6"	4x12"	4x12"	6x12"	8x12"
Approx Weight (Kg)		2400	2800	3000	3500	4000	5000	5500	6000