



AsiaElectricTechnologies

QDR series Anti-resonance Harmonic Filter Reactor for Detuned Systems



Preview

General

Electrical energy is a significant production factor for industry, and its efficient use should be a primary objective. Reducing the reactive current component by PFC correction helps to save energy.

The increasing use of modern power electronic apparatus (drives, uninterruptible power supplies, etc) that produce nonlinear current influences and loads the network with harmonics (line pollution).

The power factor correction or capacitance of the power capacitor forms a resonant circuit in conjunction with the feeding transformer. Experience shows that the self-resonant frequency of this circuit lies typically between 250 and 500 Hz, i.e. in the region of the 5th and 7th harmonics. Resonance can lead to the following undesirable effects:

- ❑ overloading of capacitors,
- ❑ overloading of transformers
- ❑ overloading of transmission equipment,
- ❑ interference with metering and control systems, computers and electrical gear,
- ❑ resonance elevation, i.e. amplification of harmonics,
- ❑ voltage distortion.

These resonance phenomena can be avoided by connecting capacitors in series with filter reactors. Detuned systems are scaled so that the self-resonant frequency is below the lowest line harmonic. The detuned PFC system is purely inductive seen by harmonics above this frequency. For the 50 Hz line frequency, the detuned system acts purely capacitively, thus correcting the reactive power.



Features:

- ❑ High harmonic overloading capability
- ❑ Very low losses
- ❑ High linearity to avoid choke tilt
- ❑ Low noise
- ❑ Simple mounting
- ❑ Long useful life
- ❑ Temperature protection (NC contact)

Filter Reactors Technical Data

Harmonics : According to DIN ENV VV61000-2-2

U3 = 0.5% U_R (ED = 100%)

U5 = 6.0% U_R (ED = 100%)

U7 = 5.0% U_R (ED = 100%)

U11 = 3.5% U_R (ED = 100%)

U13 = 3.0% U_R (ED = 100%)

Effective current : I_{rms} = √(I₁² + I₃² + ... + I₁₃²)

Fundamental current : I₁ = 1.06 * I₁ (50 Hz current of capacitor)

Rated voltage U = 415 V, f = 50 Hz, p = 6% (fr = 204 Hz)

Linearity: $L \geq 0.95 * L_N$ for current up to $1.73 * I_1$

Power KVAR	Capacitance $\mu\text{F (Star)}$	Inductance mH	I_{rms} A (I_{eff})	Losses* W	Weight kg	Drawing number	Ordering Code
10	173	3.509	14.9	71	6.5	1c	AET-QDRD6010S415
20	346	1.755	29.43	95	15	3a	AET-QDRD6020S415
25	433	1.404	37.2	105	17	3a	AET-QDRD6025S415
50	866	0.702	74.5	210	25	3b	AET-QDRD6050S415
75	1328	0.458	112.2	250	35	3c	AET-QDRD6075S415
100	1732	0.351	148.9	370	47	3d	AET-QDRD6100S415

Rated voltage U = 400 V, f = 60 Hz, p = 5.67% (fr = 252 Hz)

Linearity: $L \geq 0.95 * L_N$ for current up to $2.08 * I_1$

Power KVAR	Capacitance $\mu\text{F (Star)}$	Inductance mH	I_{rms} A (I_{eff})	Losses* W	Weight kg	Drawing number	Ordering Code
25	1173	1.02	46.1	130	16	3a	AET-QDRD5025S401
50	2346	0.51	92.2	230	26	3b	AET-QDRD5050S401
75	3519	0.34	138.2	280	34	3c	AET-QDRD5075S401
100	4692	0.255	184.3	370	48	3d	AET-QDRD5100S401

Rated voltage U = 400 V, f = 60 Hz, p = 7% (fr = 227 Hz)

Linearity: $L \geq 0.95 * L_N$ for current up to $1.73 * I_1$

Power KVAR	Capacitance $\mu\text{F (Star)}$	Inductance mH	I_{rms} A (I_{eff})	Losses* W	Weight kg	Drawing number	Ordering Code
25	1156	1.29	41.0	103	16	3a	AET-QDRD7025S401
50	2313	0.64	81.9	205	24	3b	AET-QDRD7050S401
75	3469	0.426	122.9	245	33	3c	AET-QDRD7075S401
100	4625	0.319	163.9	310	45	3d	AET-QDRD7100S401

Rated voltage U = 400 V, f = 60 Hz, p = 14% (fr = 162 Hz)

Linearity: $L \geq 0.95 * L_N$ for current up to $1.4 * I_1$

Power KVAR	Capacitance $\mu\text{F (Star)}$	Inductance mH	I_{rms} A (I_{eff})	Losses* W	Weight kg	Drawing number	Ordering Code
25	1069	2.76	38.5	130	25	2a	AET-QDRD1425S401
50	2139	1.38	77.0	250	34	3c	AET-QDRD1450S401
75	3208	0.92	115.4	340	49	3d	AET-QDRD1475S401
100	4277	0.69	154.0	400	55	3d	AET-QDRD1499S401

Rated voltage U = 400 V, f = 50 Hz, p = 14% (fr = 135 Hz)

Linearity: $L \geq 0.95 * L_N$ for current up to $1.4 * I_1$

Power KVAR	Capacitance $\mu\text{F (Star)}$	Inductance mH	I_{rms} A (I_{eff})	Losses* W	Weight kg	Drawing number	Ordering Code
10	513	8.23	15.4	87	9.4	1d	AET-QDRD1410S400
12.5	642	6.63	19.2	100	12	1e	AET-QDRD1412S400
20	1026	4.14	30.8	120	18	1f	AET-QDRD1420S400
25	1284	3.32	38.5	210	25	2a	AET-QDRD1425S400
40	2052	2.07	61.6	220	32	3c	AET-QDRD1440S400
50	2565	1.66	76.9	340	34	3c	AET-QDRD1450S400
75	3850	1.1	115.4	330	52	3d	AET-QDRD1475S400
100	5130	0.829	154	450	62	3e	AET-QDRD1499S400

*Total max. losses, considering max. specified overvoltage and harmonic currents

Rated voltage U = 440 V, f = 50 Hz, p = 5.67% (fr = 210 Hz)

Linearity: $L \geq 0.95 * L_N$ for current up to $2.08 * I_1$

Power KVAR	Capacitance $\mu\text{F (Star)}$	Inductance mH	I_{rms} A (I_{eff})	Losses* W	Weight kg	Drawing number	Ordering Code
10	465	3.7	16.8	74	7	1c	AET-QDRD5010S440
12.5	582	2.96	21.0	88	9	1d	AET-QDRD5012S440
25	1163	1.48	42.0	130	16.5	3a	AET-QDRD5025S440
50	2326	0.74	83.8	230	25	3b	AET-QDRD5050S440
75	3490	0.49	125.6	260	36	3c	AET-QDRD5075S440
100	4653	0.37	168.0	340	50	3d	AET-QDRD5100S440

Rated voltage U = 440 V, f = 60 Hz, p = 7% (fr = 227 Hz)

Linearity: $L \geq 0.95 * L_N$ for current up to $1.73 * I_1$

Power KVAR	Capacitance $\mu\text{F (Star)}$	Inductance mH	I_{rms} A (I_{eff})	Losses* W	Weight kg	Drawing number	Ordering Code
25	956	1.55	37.2	100	16	3a	AET-QDRD7025S441
50	1910	0.773	74.5	190	24	3b	AET-QDRD7050S441
75	2867	0.515	111.8	235	34	3c	AET-QDRD7075S441
100	3823	0.387	148.9	350	46	3d	AET-QDRD7100S441

Rated voltage U = 440 V, f = 60 Hz, p = 14% (fr = 162 Hz)

Linearity: $L \geq 0.95 * L_N$ for current up to $1.4 * I_1$

Power KVAR	Capacitance $\mu\text{F (Star)}$	Inductance mH	I_{rms} A (I_{eff})	Losses* W	Weight kg	Drawing number	Ordering Code
25	884	3.34	35.0	100	24	2a	AET-QDRD1425S441
50	1767	1.67	70.0	240	35	3c	AET-QDRD1450S441
75	2651	1.11	105.0	360	48	3d	AET-QDRD1475S441
100	3535	0.836	140.0	450	52	3d	AET-QDRD1499S441

Rated voltage U = 480 V, f = 60 Hz, p = 5.67% (fr = 252 Hz)

Linearity: $L \geq 0.95 * L_N$ for current up to $2.08 * I_1$

Power KVAR	Capacitance $\mu\text{F (Star)}$	Inductance mH	I_{rms} A (I_{eff})	Losses* W	Weight kg	Drawing number	Ordering Code
25	814	1.47	38.3	130	18	1f	AET-QDRD5025S481
50	1629	0.74	76.8	300	31	3c	AET-QDRD5050S481
75	2445	0.49	115.1	230	33	3c	AET-QDRD5075S481
100	3258	0.367	153.6	400	47	3d	AET-QDRD5100S481

Rated voltage U = 480 V, f = 60 Hz, p = 7% (fr = 227 Hz)

Linearity: $L \geq 0.95 * L_N$ for current up to $1.73 * I_1$

Power KVAR	Capacitance $\mu\text{F (Star)}$	Inductance mH	I_{rms} A (I_{eff})	Losses* W	Weight kg	Drawing number	Ordering Code
12.5	402	3.68	17.0	71	6.5	1c	AET-QDRD7012S481
25	804	1.84	34.2	103	13.2	1e	AET-QDRD7025S481
50	1605	0.92	68.4	240	24.2	3b	AET-QDRD7050S481
75	2409	0.61	102.4	270	32	3c	AET-QDRD7075S481
100	3213	0.46	136.7	270	35	3c	AET-QDRD7100S481

Rated voltage U = 480 V, f = 60 Hz, p = 14% (fr = 162 Hz)

Linearity: $L \geq 0.95 * L_N$ for current up to $1.4 * I_1$

Power KVAR	Capacitance $\mu\text{F (Star)}$	Inductance mH	I_{rms} A (I_{eff})	Losses* W	Weight kg	Drawing number	Ordering Code
25	742	4.0	32.1	155	20	2a	AET-QDRD1425S481
50	1485	2.0	64.1	280	34	3c	AET-QDRD1450S481
75	2229	1.33	96.2	350	48	3d	AET-QDRD1475S481
100	2970	1.0	128.2	430	53	3d	AET-QDRD1499S481

*Total max. losses, considering max. specified overvoltage and harmonic currents



QDR series Anti-resonance Harmonic Filters

Rated voltage U = 440 V, f = 60 Hz, p = 5.67% (fr = 252 Hz)

Linearity: $L \geq 0.95 * L_N$ for current up to $2.08 * I_1$

Power KVAR	Capacitance μF (Star)	Inductance mH	I_{rms} A (I_{eff})	Losses* W	Weight kg	Drawing number	Ordering Code
25	969	1.235	42.0	125	18	3a	AET-QDRD5025S441 18
50	1939	0.617	83.8	210	25	3b	AET-QDRD5050S441 18
75	2908	0.412	126.0	300	33	3c	AET-QDRD5075S441 12
100	3877	0.309	167.4	400	47	3d	AET-QDRD5100S441 1

Rated voltage U = 440 V, f = 50 Hz, p = 14% (fr = 135 Hz)

Linearity: $L \geq 0.95 * L_N$ for current up to $1.4 * I_1$

Power KVAR	Capacitance μF (Star)	Inductance mH	I_{rms} A (I_{eff})	Losses* W	Weight kg	Drawing number	Ordering Code
10	424	10	14.0	87	10	1d	AET-QDRD1410S440 40
12.5	530	8.03	17.5	95	13	1e	AET-QDRD1412S440 18
25	1060	4	35.0	130	26	2a	AET-QDRD1425S440 18
50	2121	2.12	70.0	260	40	3c	AET-QDRD1450S440 1
75	3181	1.34	105.0	350	52	3d	AET-QDRD1475S440 1
100	4242	1	140.0	440	66	3d	AET-QDRD1499S440 1

*Total max. losses, considering max. specified overvoltage and harmonic currents

Dimensional Drawings

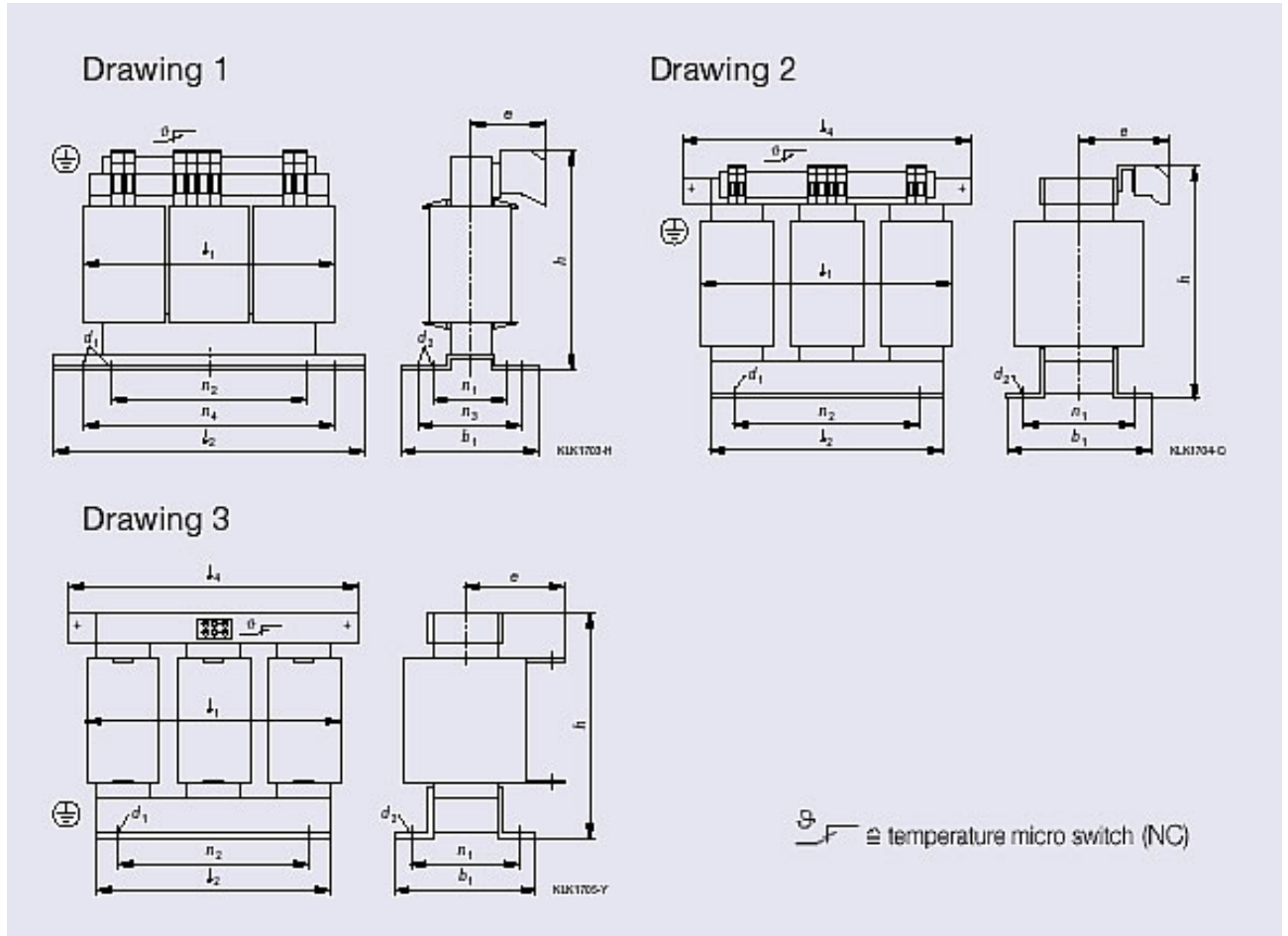

Drawing 1

	b1	d1	d2	d3	e	h	l1	l2	n1	n2	n3	n4
a	73	5.8	11	M5	60	159	150	178	49	113	53	166
b	88	5.8	11	M5	67	159	150	178	64	113	68	166
c	99	7	13	M6	62	181	182	219	56	136	69	201
d	119	7	13	M6	72	181	182	219	76	136	89	201
e	107	7	13	M6	66	221	228	267	70	176	77	249
f	131	7	13	M6	79	221	228	267	94	176	101	249

Insulation class B: 130 °C

Drawing 2

	b1	d1	d2	d3	e	h	l1	l2	l4	n1	n2
a	162	10	18	M8	108	291	264	220	270	101	200

Insulation class H: 180 °C

Drawing 3

	b1	d1	d2	d3	e	h	l1	l2	l4	n1	n2
a	115	7	12	M6	103	210	228	190	-	94	176
b	177	10	18	M8	121	260	270	270	270	135	240
c	190	10	18	M8	137	269	300	250	300	118	264
d	211	10	18	M8	142	321	360	300	350	138	284
e	216	12	18	M10	171	385	405	350	410	141	336

Insulation class H: 180 °C